

SERIE PRISMA

PRISMA15, PRISMA25, PRISMA35N Y PRISMA45N

BOMBA MULTITAPAS HORIZONTAL

SERIE PRISMA

PRISMA15, PRISMA25, PRISMA35N Y PRISMA45N

ESPECIFICACIONES

Bombas centrífugas multietapas horizontales para aplicaciones de bombeo de agua limpia donde se requiera una bomba robusta y compacta. Destaca por su operación extremadamente silenciosa y su capacidad autoaspirante hasta 2 m.

APLICACIONES

- Suministro de agua a viviendas.
- Sistemas de riego.
- Sistemas hidroneumáticos.
- Sistemas de presión constante.

MATERIALES

- Camisa(tubo envolvente) en acero inoxidable 304
- Eje motor en acero inoxidable 420
- Impulsores en acero inoxidable 304
- Difusores fabricados en tecnopolímero Noryl® (PPO con Carga de fibra de vidrio)
- Cuerpo de aspiración e impulsión en hierro fundido
- Sello mecánico de Grafito/alúmina
- Carcasa del motor en aluminio

MOTOR

- Asíncrono, dos polos
- Protección IP 55
- Aislamiento clase F
- Servicio continuo

CARACTERÍSTICAS DE OPERACIÓN

- Temperatura del líquido: 4°C hasta 40°C
- Autoaspirante a 2 m.c.a

DESCRIPCIÓN DEL CÓDIGO

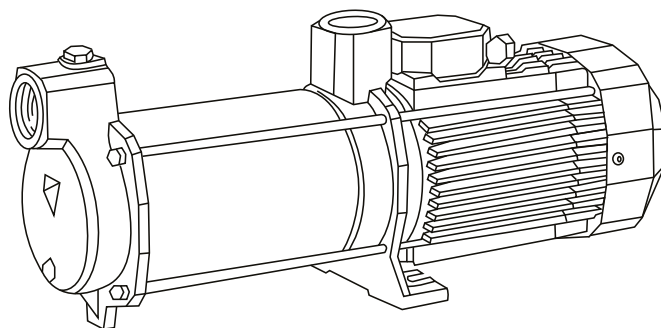
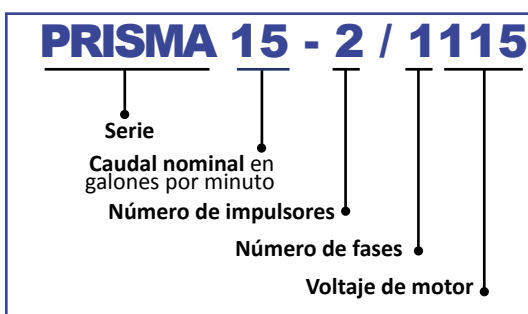

CURVAS DE OPERACIÓN

PRISMA 15



TABLA DE ESPECIFICACIONES

BOMBAS CENTRÍFUGAS MULTIETAPAS HORIZONTALES MARCA ESPA Serie PRISMA

CÓDIGO	HP	KW	FASES X VOLTS	AMP.	SUCCIÓN X DESCARGA (pulgadas)	DMS*	PRESIÓN AL CIERRE (m/psi)	CARGA EN METROS (psi)				
								10 (14.2)	20 (28.4)	30 (42.6)	40 (56.8)	50 (71)
								GASTO (lpm)				
PRISMA15-2/1115	1/2	0.37	1 x 115	5.8	1" x 1"	1.25"	34/48	68	51	22		
PRISMA15-3/1115	3/4	0.55		8.5			50/71	75	63	49	32	
PRISMA15-3/1220			1 x 220	4.7								

Nota: Las bombas PRISMA trifásicas pueden ser conectadas a 220V o 440V según sea necesario, siguiendo el diagrama descrito en la caja de conexiones.

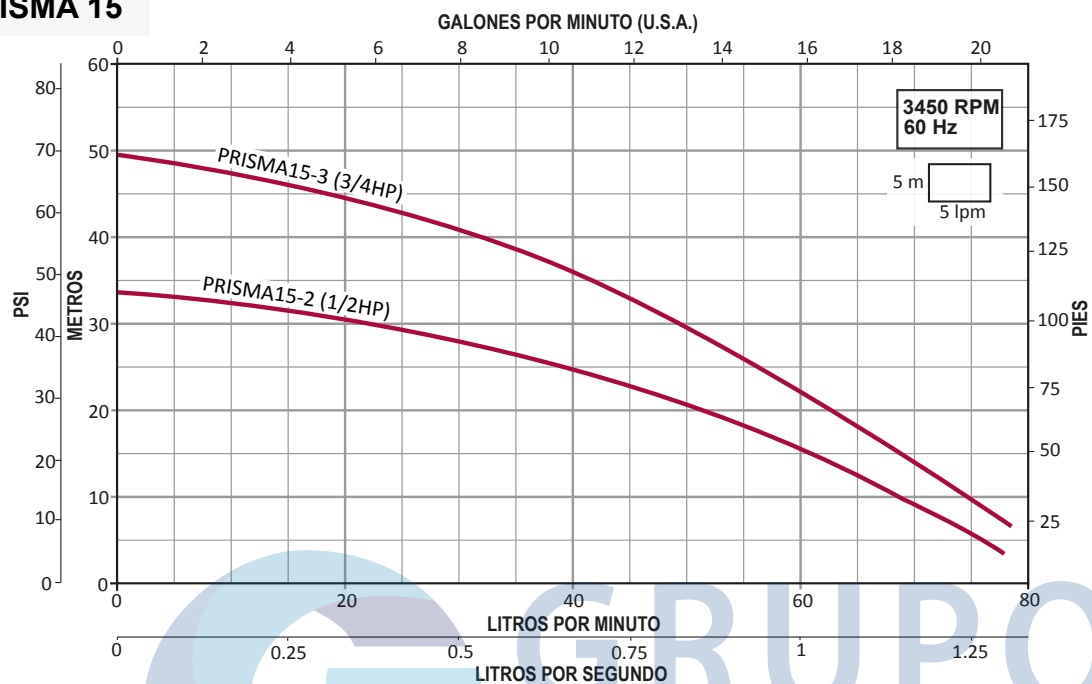
DIMENSIONES Y PESO

CÓDIGO	DIMENSIONES (mm)										Kg.
	A	B	C	D	E	F	G	H	I	J	
PRISMA15-2/1115	163	213	202	110	74	162	121	102	1"	1"	8.6
PRISMA15-3/1115	187	237	202	110	74	162	121	102	1"	1"	9.2
PRISMA15-3/1220	187	237	202	110	74	162	121	102	1"	1"	9.2

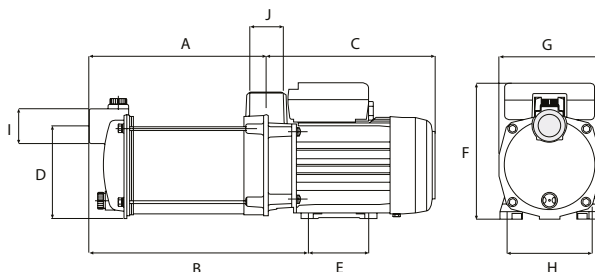

CURVAS DE OPERACIÓN

PRISMA 25



TABLA DE ESPECIFICACIONES

BOMBAS CENTRÍFUGAS MULTIETAPAS HORIZONTALES MARCA ESPA Serie PRISMA

CÓDIGO	HP	KW	FASES X VOLTS	AMP.	SUCCIÓN X DESCARGA (pulgadas)	DMS*	PRESIÓN AL CIERRE (m/psi)	CARGA EN METROS (psi)					
								10 (14.2)	20 (28.4)	30 (42.6)	40 (56.8)	50 (71)	60 (85.2)
								GASTO (lpm)					
PRISMA25-2/1115	1	0.75	1 x 115	11.5	1" x 1"	1.25"	34/48		108	55			
PRISMA25-2/1220			1 x 220	6									
PRISMA25-3/1115	1.5	1.1	1 x 115	16.5			50/71		112	82			
PRISMA25-3/1220			1 x 220	8.3									
PRISMA25-4/1220	2	1.5		12			66/93			114	92	65	
PRISMA25-4/3220			3x220/440	6.5/3.8									

Nota: Las bombas PRISMA trifásicas pueden ser conectadas a 220V o 440V según sea necesario, siguiendo el diagrama descrito en la caja de conexiones.

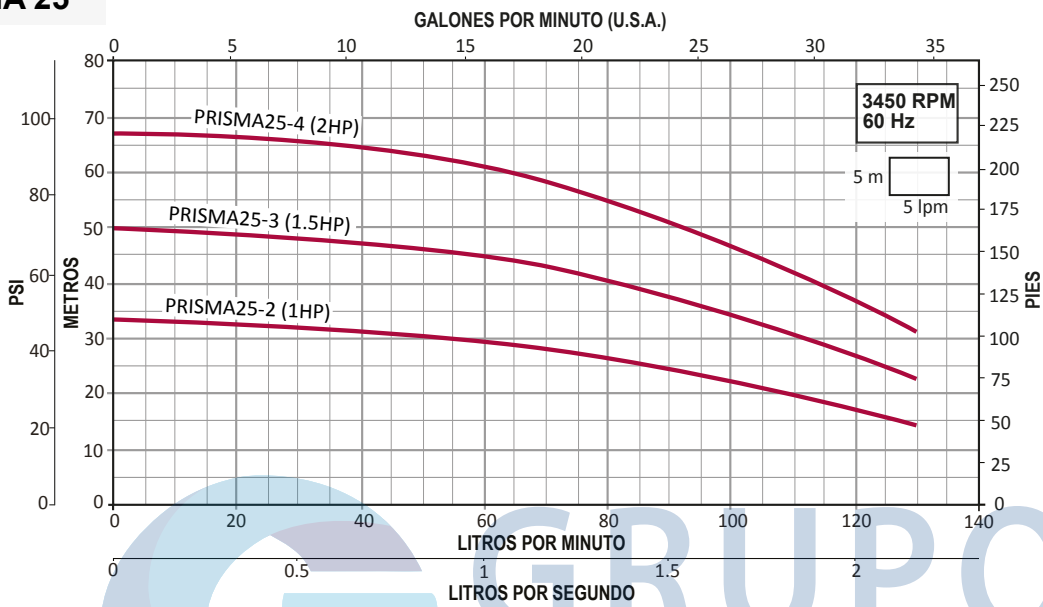
DIMENSIONES Y PESO

CÓDIGO	DIMENSIONES (mm)										Kg.
	A	B	C	D	E	F	G	H	I	J	
PRISMA25-2/1220	175.5	226	218	127	82	184.5	138	118	1"	1"	14
PRISMA25-2/1115	175.5	226	218	127	82	184.5	138	118	1"	1"	14
PRISMA25-3/1115	202	225	286	142	20	212	154	138	1"	1"	18.5
PRISMA25-3/1220	202	225	286	142	20	212	154	138	1"	1"	18.5
PRISMA25-4/1220	229	252	286	142	20	212	154	138	1"	1"	21.2
PRISMA25-4/3220	229	252	286	142	20	212	154	138	1"	1"	18.5

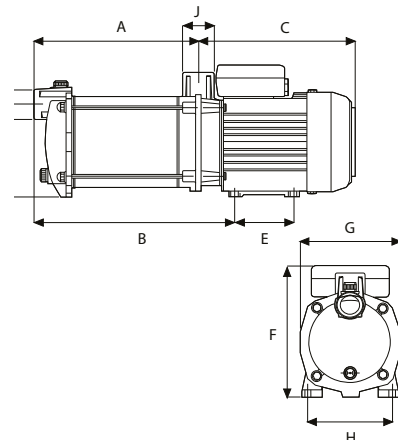

CURVAS DE OPERACIÓN PRISMA 35N



TABLA DE ESPECIFICACIONES

CÓDIGO	HP	KW	FASES X VOLTS	AMP.	SUCCIÓN X DESCARGA (pulgadas)	DMS*	PRESIÓN AL CIERRE (m/psi)	CARGA EN METROS (psi)					
								15 (21.3)	20 (28.4)	30 (42.6)	40 (56.8)	50 (71)	60 (85.2)
								GASTO (lpm)					
PRISMA35N-2/1220	1.5	1.1	1x220	8.1	1.25"x1.25"	1.5"	42/59	198	175	128	48		
PRISMA35N-2/3224				5.2/3									
PRISMA35N-3/3224	2	1.5	3x220/440	7.3/4.2			64/90		203	175	144	107	50
PRISMA35N-4/3224	3	2.2		9/5.2			78/110		204	180	157	130	100

DIMENSIONES Y PESO

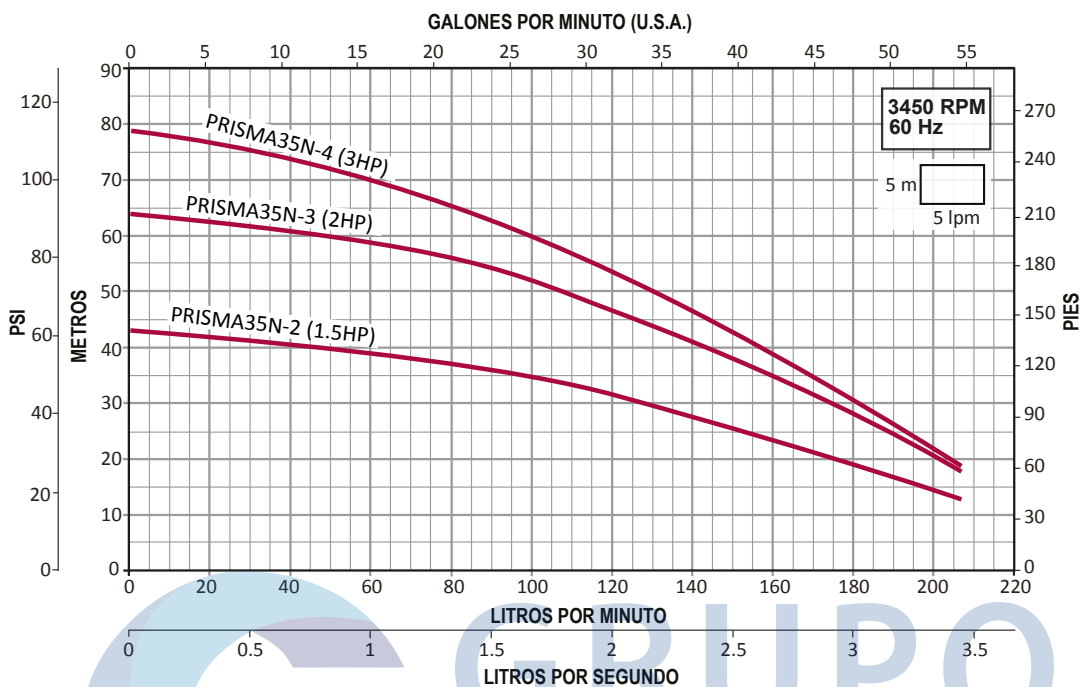
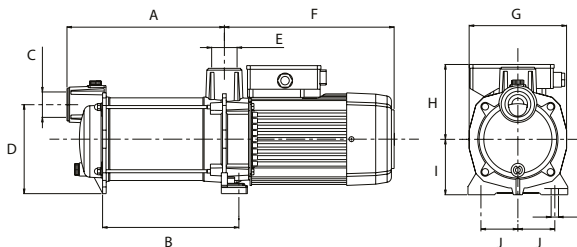

CÓDIGO	DIMENSIONES (mm)											Kg.
	A	B	C	D	E	F	G	H	I	J	K	
PRISMA35N-2/1220	197.6	162.8	1 1/4"	147	1 1/4"	281.5	158	125.3	90	60	12	19.7
PRISMA35N-2/3224	197.6	162.8	1 1/4"	148	1 1/4"	281.5	158	125.3	90	60	12	19.4
PRISMA35N-3/3224	222.1	187.3	1 1/4"	147	1 1/4"	281.5	158	125.3	90	60	12	22.7
PRISMA35N-4/3224	246.6	211.8	1 1/4"	147	1 1/4"	281.5	158	125.3	90	60	12	22.8

CURVAS DE OPERACIÓN

PRISMA 45N



TABLA DE ESPECIFICACIONES

CÓDIGO	HP	KW	FASES X VOLTS	AMP.	SUCCIÓN X DESCARGA (pulgadas)	DMS*	PRESIÓN AL CIERRE (m/psi)	CARGA EN METROS (psi)					
								10 (14.2)	20 (28.4)	30 (42.6)	40 (56.8)	50 (71)	60 (85.2)
								GASTO (lpm)					
PRISMA45N-2/1220	2	1.5	1 x 220	10.5	1.5" x 1.25"	2"	38/53	290	232	152			
PRISMA45N-2/3224		1.5	3x220/440	8.7/4.7									
PRISMA45N-3/3224	3	2.2			8.6/4.7		55/78	311	273	228	180	100	

DIMENSIONES Y PESO

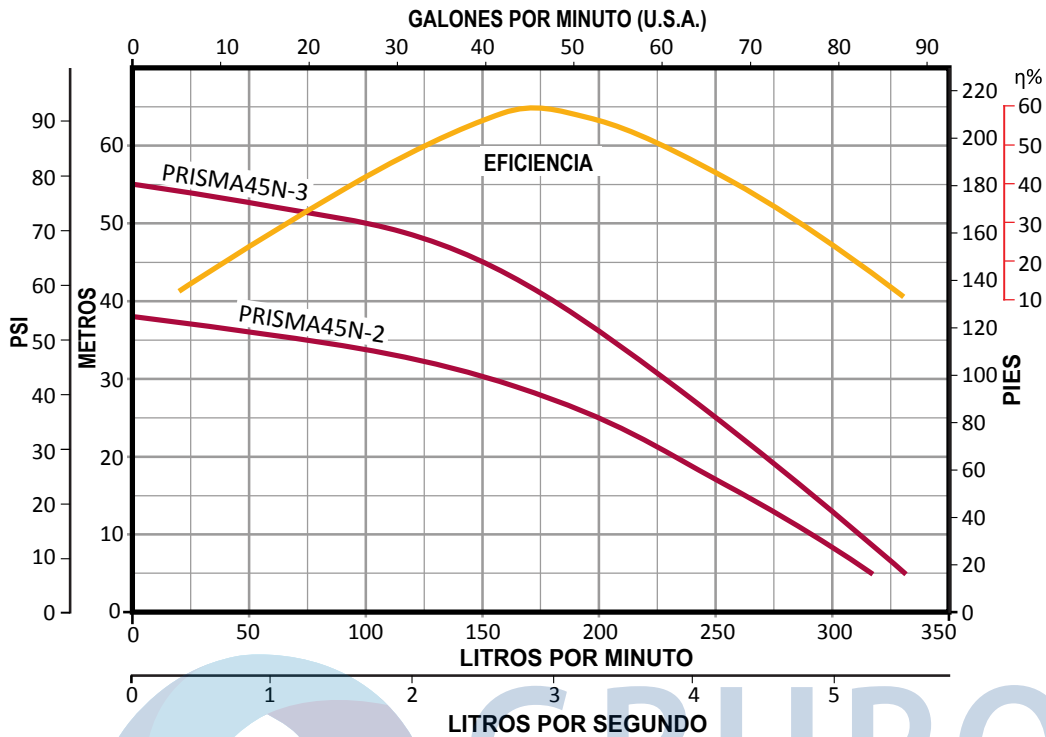
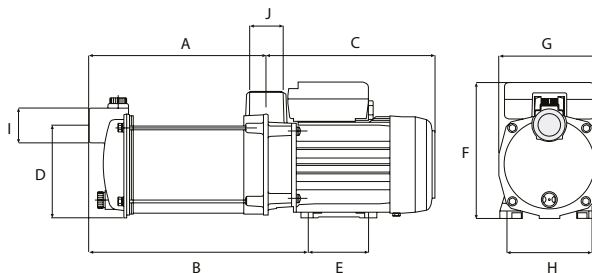

CÓDIGO	DIMENSIONES (mm)											Kg.
	A	B	C	D	E	F	G	H	I	J	K	
PRISMA45N-2/1220	215.2	180.9	1 1/2"	152	1 1/4"	281.5	158	125.3	90	60	12	22.5
PRISMA45N-2/3224	215.2	180.9	1 1/2"	153	1 1/4"	281.5	158	125.3	90	60	12	20.1
PRISMA45N-3/3224	245.9	211.6	1 1/2"	152	1 1/4"	281.5	158	125.3	90	60	12	22.9



**BOMBA MULTIETAPAS
HORIZONTAL**

PRISMA

